

McIntosh  
MC 2300

# OWNER'S MANUAL

THE McINTOSH MC 2300 SOLID STATE STEREO POWER AMPLIFIER

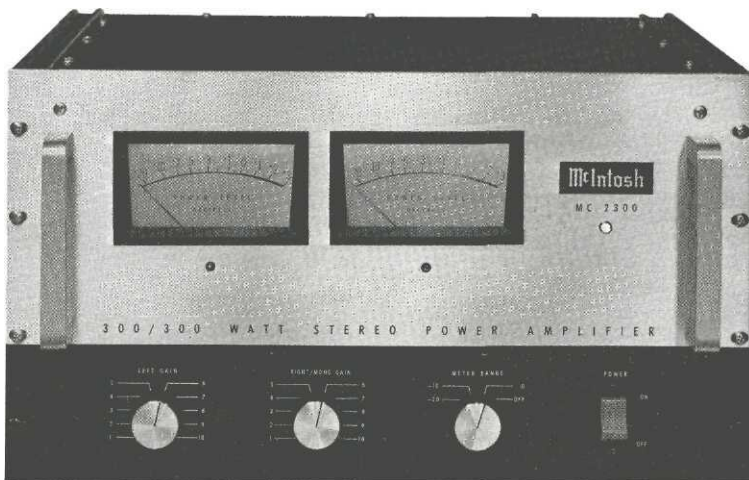

Price \$1.25



**The McIntosh MC 2300 is a high quality, extremely high power, solid state stereo amplifier. Because of the high power available it is necessary to emphasize some prudent and safe operating conditions.**

- 1. Never connect or disconnect inputs or outputs while the amplifier is turned on. Loudspeakers can be damaged or destroyed by the high power available from the instrument.**
- 2. Never operate the amplifier with the power cord plugged into an auxiliary AC power outlet on source equipment. The amplifier draws near 14 amperes at full power and damage to the source equipment can occur.**
- 3. Do not operate the instrument plugged into an ordinary extension cord. Heavy duty extension cords (14 ga. or heavier) have adequate wire size and will not overheat.**
- 4. Be cautious when lifting the instrument. It weighs 128 pounds. Make certain that what it is placed on can support the weight.**

Your MC 2300 Stereo Power Amplifier will give you many years of pleasant and satisfactory performance. If you have any questions concerning the operation or maintenance of this instrument, please contact:

## CUSTOMER SERVICE

McIntosh Laboratory Inc.  
2 Chambers Street  
Binghamton, New York 13903  
Phone: 607-723-3512

Take Advantage of 3 years  
of FREE Factory Service . . .  
Fill in the Application NOW.

# CONTENTS

GUARANTEE....	1
INSTALLATION....	3
HOW TO CONNECT....	4,5
Stereophonic....	6
Monophonic....	7
FRONT PANEL INFORMATION....	8
PERFORMANCE LIMITS....	9
TYPICAL PERFORMANCE CHARTS....	10
TECHNICAL DESCRIPTION....	11
BLOCK DIAGRAM....	16

## GUARANTEE

McIntosh Laboratory Incorporated guarantees this Instrument to be capable of performance as advertised. We also guarantee the mechanical and electrical workmanship and components to be free of defects for a period of 90 days from date of purchase. If such defects occur, McIntosh Laboratory

or one of its authorized agencies will repair the defect at no cost to the purchaser. This guarantee does not extend to components damaged by improper use nor does it extend to transportation to and from the factory or service agency.

An application for a FREE THREE YEAR FACTORY SERVICE CONTRACT is included with this manual. The terms of the contract are:

For Three Years from date of purchase —

1. McIntosh will provide all parts, materials and labor needed to return the measured performance of the instrument to the original performance limits free of any charge. The SERVICE CONTRACT does not cover any shipping costs to and from the authorized service agency or the factory.
2. Any McIntosh authorized service agency will repair all McIntosh instruments at normal service rates. To receive the free service under the terms of the SERVICE CONTRACT, the SERVICE CONTRACT CERTIFICATE must accompany the instrument when taken to the service agency.
3. Always have service done by a McIntosh authorized service agency. If the instrument is modified or damaged, as a result of unauthorized repair the SERVICE CONTRACT will be cancelled. Damage by improper use or mishandling is not covered by the SERVICE CONTRACT.

4. The SERVICE CONTRACT is issued to you as the original purchaser. To protect you from misrepresentation this contract cannot be transferred to a second owner.
5. The SERVICE CONTRACT is given to purchasers who live in the 50 United States or Canada only.
6. For your protection McIntosh selects its dealers carefully. Only one dealer in ten qualifies for a McIntosh franchise. To receive the SERVICE CONTRACT your purchase must be made from a McIntosh franchised dealer.
7. Your completely filled in application for a SERVICE CONTRACT must be postmarked within 30 days of the date of purchase of the instrument.
8. To receive the SERVICE CONTRACT all information on the application must be filled in. The SERVICE CONTRACT will be issued when the completely filled in application is received at McIntosh Laboratory Incorporated in Binghamton, New York. If the application is not received at McIntosh Laboratory, only the service offered under the 90-day guarantee will apply.

# Installation

Installation of the MC 2300 requires careful thought about three important factors. They are the electrical power to operate the unit, the weight and the heat generated when the MC 2300 is operating.

The MC 2300 draws 1400 watts or about 14 amperes when operated at full power. Do not use ordinary extension cords of any type. Heavy duty extension cords (14 ga. or heavier) have adequate wire size and will not overheat. Plug the AC power cord directly into a wall outlet. Make certain that the AC power outlet has at least 15 amperes capacity with nothing else using the circuit. Do not plug the MC 2300 into an auxiliary AC power outlet on a pre-amplifier or other source equipment. If remote power operation is required, an external relay arrangement must be made.

Weight of the instrument is 128 pounds. Make certain that the shelf on which it is to be mounted can support that weight. If it is to be vertically mounted, be certain the structure is capable of supporting the MC 2300.

Adequate ventilation extends the trouble-free life of electronic instruments. It is generally found that each 10° centigrade (18° F) rise in temperature reduces the life of electrical insulation by one half. Adequate ventilation is an inexpensive and effective means of preventing insulation breakdown that results from unnecessarily high operating temperatures. The direct benefit of adequate ventilation is longer, trouble-free life. Provide a source for input air and an outlet for the heated air. The heat generated in the operation of the MC 2300 is exhausted from the unit by two low noise, long life fans.

Cooling input air is drawn into the MC 2300 through the ventilation holes on the sides of the MC 2300. The air passes over the transformers, output heat sinks and transistors; and, is blown out the back of the instrument by the two fans. It is recommended that at least 2 inches of clear space be provided on each side.

To permit the fans to operate best, provide at least 5 inches of space at the rear of the instrument. A source for input air and a means to exhaust the heated air is necessary so that the heated air does not recirculate through the MC 2300.

To install the unit in a cabinet the aluminum side rails with the feet attached must be removed. The

rails are attached to the front panel by 8 #10-32 machine screws and to each side by 4 small clips. Remove both the front panel screws and the four clips from each side for cabinet mounting. The opening to fit the unit is 17¼ by 10¼ inches.

## RACK INSTALLATION

The MC 2300 may be mounted in a standard 19" rack by removing the aluminum side rails. If a standard rack is used, the screws that held the aluminum rails to the front panel are used to attach the MC 2300 to the rack. When rack mounted, the MC 2300 requires 10½ inches of panel space. Allow two inches in front of the panel for the knobs. A depth of 17 inches plus ventilation space is required.

The MC 2300 can be slide mounted in a rack. Tapped well nuts and internal structure bracing has been added to both sides of the MC 2300 for use with the Model CTS-116 side mounted slide assemblies manufactured by Chassis-Trak Inc., Indianapolis, Indiana.

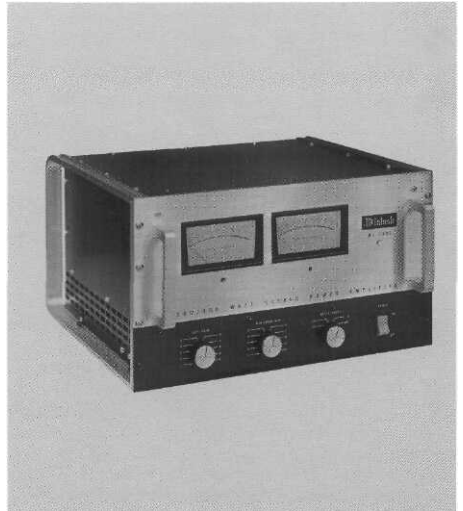

# How to Connect

## INPUT

### Stereo or twin amplifier operation:

Use shielded cables to connect the signal from the preamplifier or signal source to the power amplifier. All connection are made on the back panel of the MC 2300.

For stereo operation the LEFT OUTPUT of the pre-amplifier should be connected to the LEFT INPUT of the power amplifier. The RIGHT OUTPUT of the pre-amplifier should be connected to the RIGHT/MONO input of the power amplifier. In stereo or twin amplifier operation the MODE SWITCH must be in the stereo position.

For twin amplifier operation a separate signal source can be connected to each input.

To minimize the possibility of hum the shielded leads shall be run parallel or loosely twisted together. Locate the cables away from AC power cords.

### Monophonic or Single Channel operation:

A shielded cable from the signal source is connected to the RIGHT/MONO input of the MC 2300. The MODE SWITCH on the back panel of the amplifier must be placed in the MONO position. In the MONO position the output of the right channel input amplifier is fed to both left and right power amplifiers. The LEFT INPUT is disconnected. Only the signal fed into the RIGHT/MONO input will be amplified. Should the MODE SWITCH be left in the STEREO position and the output transformers be strapped to a monophonic load, one channel will attempt to drive the other and cause high circulating currents and overheating. **Be certain that the MC 2300 is never operated in the stereo mode with the outputs connected for monophonic operation.**

## OUTPUT

### Stereo or twin amplifier operation:

To connect the left speaker first check the impedance of the speaker which is usually identified on the speaker itself or in the owner's manual. Connect one lead from the common terminal of the speaker to the LEFT CHANNEL OUTPUT terminal strip screw COMMON. Connect the other terminal of the speaker to the screw with the number corresponding to the speaker impedance on the LEFT CHANNEL OUTPUT terminal strip. The right channel speaker is connected in the same manner on the RIGHT CHANNEL OUTPUT terminal strip. For stereo or twin channel

operation it is not necessary to use the same impedance loudspeaker on each output. Connect each channel for the impedance desired.

When multiple speakers are to be connected to either or both outputs, the combined load impedance must be calculated and the load connected to the appropriate impedance tap. The following table will aid in selecting the correct impedance match.

Load impedance in ohms	Connect to	Load impedance in ohms	Connect to
0.4 to 0.9	0.5	3.6 to 7.2	4
0.9 to 1.8	1	7.2 to 14.4	8
1.8 to 3.6	2	14.4 to 28	16

If a load impedance is used that is lower than the output impedance tap, then reduced power and possible distortion will result. If a load impedance is used that is higher than the output impedance tap, then neither the signal nor the amplifier will be harmed but the voltage available is limited to that stated at that tap.

### For constant voltage line operation:

25 volts	Connect to 2 ohms
70 volts	Connect to 16 ohms

Make all speaker connections at the amplifier only. For multiple speaker operation, parallel the leads from the speakers to the amplifier.

Because of the high power available from the MC 2300, be sure to use large diameter speaker leads. In all cases, the leads to and from the speaker should be twin conductor or twisted together.

Use lamp cord, bell wire, or wire with similar type of insulation to connect the speakers to the amplifier. For the normally short distances of under 20 feet between the amplifier and speaker #18 wire or larger can be used. For distances over 20 feet between the amplifier and speaker use larger diameter wire. Select the correct size wire for the wire distance from the chart.

It is recommended that the DC resistance of the speaker leads not be over 5% of the load impedance. Up to 10% can be tolerated. Resistance of the leads should be computed for the length of wire both to and from the speaker or speakers.

### Monophonic or Single Channel operation:

When the MC 2300 is used as a monophonic or single channel power amplifier the two channels are combined to produce output up to 600 watts. The output must be tied together at the appropriate load impedance tap. In connecting a load to the MC 2300 for single channel operation connect the common side of the load to the LEFT CHANNEL OUTPUT terminal marked COM., the other lead as below.

If the speaker or load Impedance is:	The hot side of the line is connected to:	Connect a jumper wire between:
0.25 ohms	Left 0.5	Left 0.5 and Right 0.5
0.5 ohms	Left 1	Left 1 and Right 1
2 ohms	Left 4	Left 4 and Right 4
4 ohms	Left 8	Left 8 and Right 8
8 ohms	Left 16	Left 16 and Right 16

If the load impedance is between any of the above figures select the best impedance match from this chart:

Load Impedance in ohms	Connect to	Load Impedance in ohms	Connect to
0.4 to 0.9	0.5	3.6 to 7.2	4
0.9 to 1.8	1	7.2 to 14.4	8
1.8 to 3.6	2	14.4 to 28	16

### For monophonic constant voltage line operation:

If the output voltage is:	The hot side of the load is connected to:	Connect a jumper wire between
25 volts	Left 2	Left 2 and Right 2
70 volts	Left 16	Left 16 and Right 16

Make all speaker connections at the amplifier only. For multiple speaker operation, parallel the leads from the speakers to the amplifier.

Should the MODE SWITCH be left in the STEREO position and the output transformers be strapped to a monophonic load, one channel will attempt to drive the other and cause circulating currents and overheating. **Be certain that the MC 2300 is never operated in the stereo mode with the outputs connected for monophonic operations.**

### AC POWER

The MC 2300 is designed to operate on 117 to 130 volts 50/60 Hz. Do not use ordinary extension cords of any type. Heavy duty extension cords (14 ga. or heavier) have adequate wire size and will not overheat. Plug the the AC power cord directly into a wall outlet. Make certain that the AC power outlet has at least 15 ampere capacity with nothing else using the circuit. Do not plug the MC 2300 into an auxiliary AC power outlet on a preamplifier or other source equipment unless it is known there is adequate current capacity. If remote power operation is required, an external relay arrangement must be made.

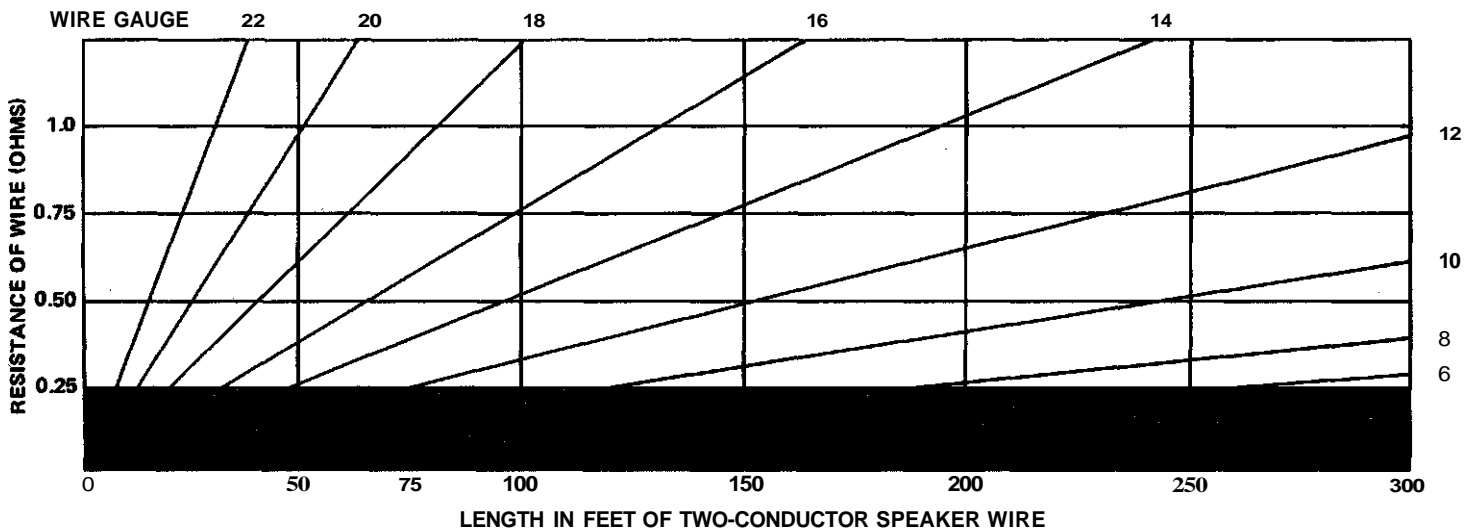

# STEREOPHONIC CONNECTIONS

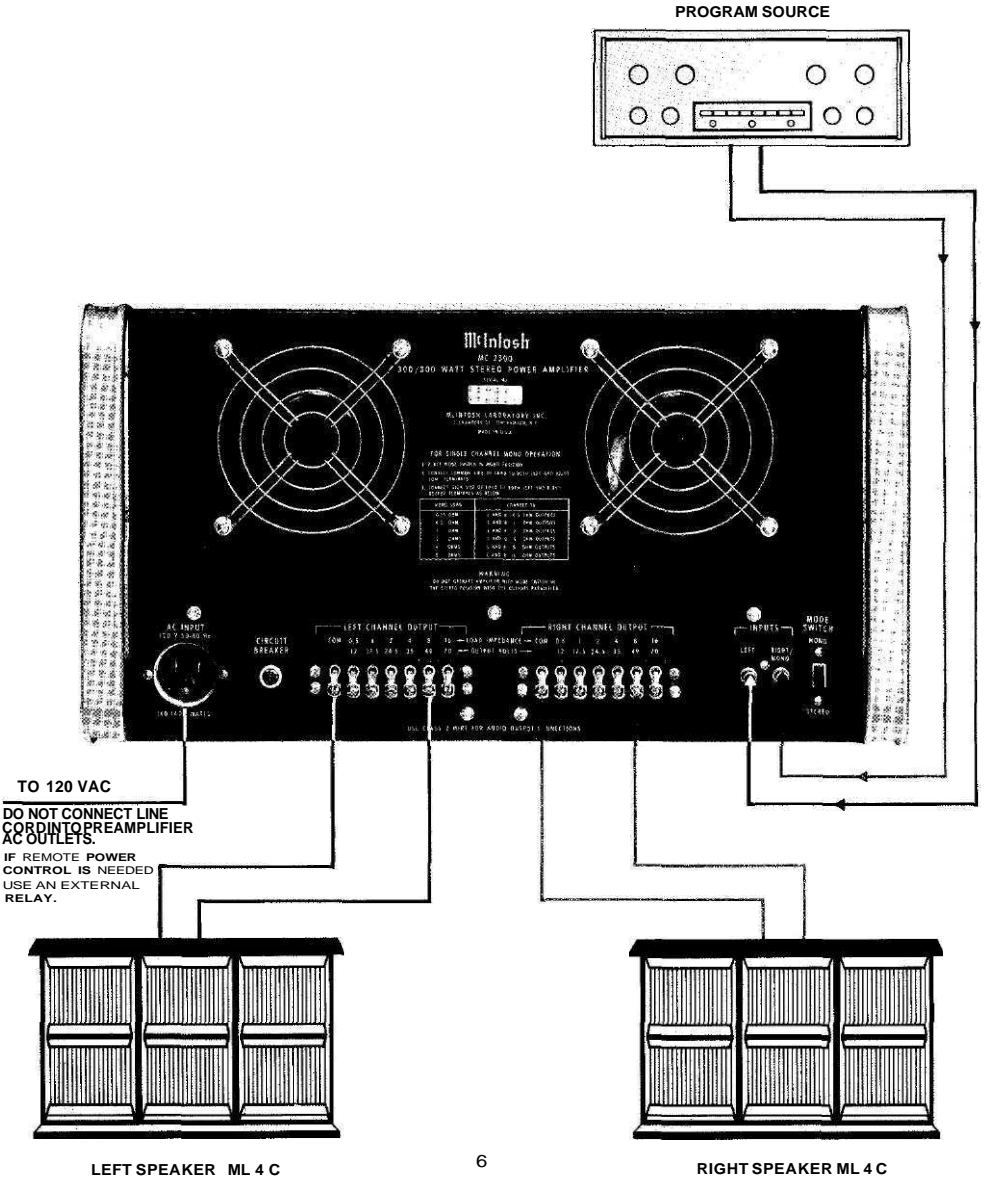



# MONOPHONIC CONNECTIONS

PROGRAM SOURCE

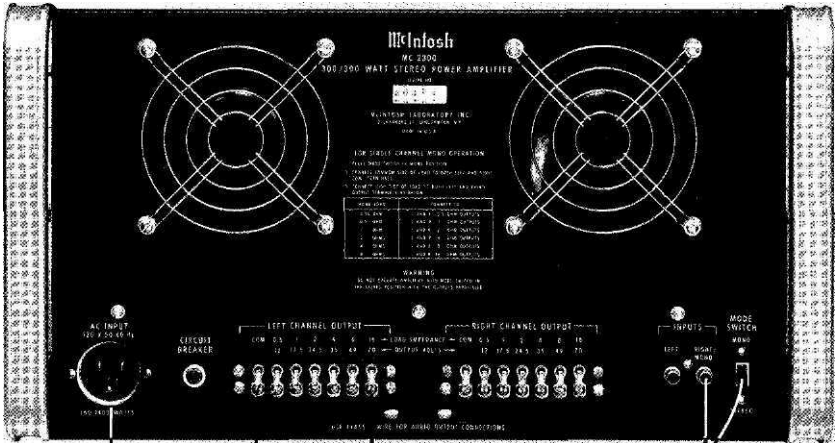
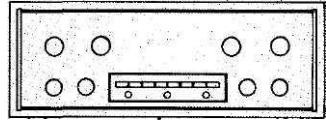

To 120 VAC

**DO NOT CONNECT LINE  
AC OUTLETS.  
IF REMOTE POWER  
CONTROL IS NEEDED USE  
AN EXTERNAL RELAY.**

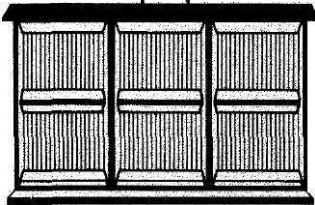

ML4 CLOUDSPEAKER

MODE SWITCH  
MONO

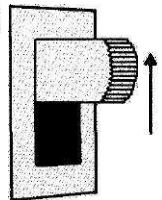

STEREO

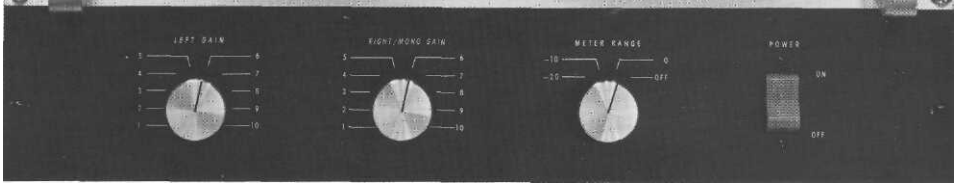

## Front Panel Information

### LEFT GAIN

The left gain control is used to control gain or volume of the left channel. Clockwise rotation increases gain.

### RIGHT/MONO GAIN

In stereo the RIGHT/MONO GAIN control determines the gain or volume of the right channel only. Clockwise rotation increases gain. If the MC 2300 is connected as a monophonic or single channel amplifier, the gain or volume is controlled by the RIGHT/MONO GAIN control.

Both controls have a standard volume control taper. The numerals around the controls are provided for reference. They do not represent relative output versus rotation.

### METER RANGE

The meter switch has four positions. The first position is OFF. With switch in the OFF position there is no indication on the meters.

0: In this position of the meter range switch, the amplifier will deliver 300 watts when the meter indicates +3 dB, with meter indication of "0," the amplifier delivers 150 watts, with a meter indication of -3 dB, the amplifier delivers 75 watts.

-10: In this position of the meter range switch, the amplifier will deliver 15 watts output when the meter indicates "0."

-20: In this position of the meter range switch, the amplifier will deliver 1.5 watt when the meter indicates "0."

Two meters monitor and indicate the output power in each channel. The meters indicate peak power output of the monitored channel. To assure more accurate indications of peak power, McIntosh's peak locking circuits stretch the peak reading of rapid changing information long enough to give adequate visual perception. Ordinary meters lack the capability of indicating the short interval of power in a sound wave. The mass of the meter movement is too great to respond to the nearly instantaneous changes in music program material. McIntosh has developed circuits that permit the meters of the MC 2300 to respond to the short interval power in a sound wave to an accuracy of 98%.

Monitoring of the output power is done at the primary or input of the autoformer resulting in true power readings regardless of output impedance selected.

The graph represents the relationship between the meter reading and power output for all three meter ranges:

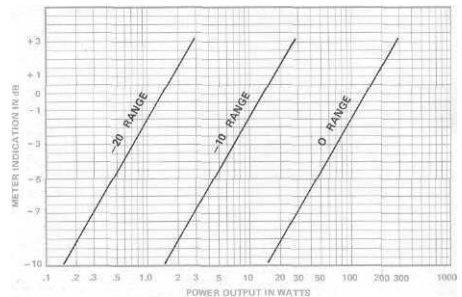

### POWER

The power switch turns the MC 2300 on or off. If you wish to control the on/off operation of the amplifier remotely, use a control relay in series with the power line and leave the power switch in the ON position. Do not plug the MC 2300 into any of the auxiliary AC power outlets of the preamplifier or other associated equipment unless that equipment has power capacity for handling 1400 watts (14 amperes).

# Performance Limits

## PERFORMANCE GUARANTEE

Performance Limits are the maximum deviation from perfection permitted for a McIntosh instrument. We promise you that the MC 2300 you buy must be capable of performance at or exceeding these limits or you get your money back. McIntosh is the only

## POWER OUTPUT

STEREO: 300 watts continuous, both channels operating; which is:

- 12.2 volts RMS across 0.5 ohm
- 17.3 volts RMS across 1 ohm
- 24.5 volts RMS across 2 ohms
- 34.6 volts RMS across 4 ohms
- 49.0 volts RMS across 8 ohms
- 69.3 volts RMS across 16 ohms

MONO: 600 watts continuous; which is:

- 12.2 volts RMS across 0.25 ohm
- 17.3 volts RMS across 0.5 ohm
- 24.5 volts RMS across 1 ohm
- 36.6 volts RMS across 2 ohms
- 49.0 volts RMS across 4 ohms
- 69.3 volts RMS across 8 ohms

## HARMONIC DISTORTION

Stereo:

Less than 0.25% at 300 watts output from 20 Hz to 20,000 Hz both channels operating. Typical performance is less than 0.1% at rated power. Distortion decreases as output power is reduced.

Mono:

Less than 0.25% at 600 watts output from 20 Hz to 20,000 Hz. Typical performance is less than 0.1% at rated power. Distortion decreases as output power is reduced.

## INTERMODULATION DISTORTION

Stereo:

Less than 0.25% if instantaneous peak power is 600 watts or less per channel with both channels operating for any combination of frequencies 20 Hz to 20,000 Hz.

Mono:

Less than 0.25% if instantaneous peak power is 1200 watts or less for any combination of frequencies 20 Hz to 20,000 Hz.

## FREQUENCY RANGE

Stereo:

- 20 Hz to 20,000 Hz, +0 - 0.5 dB at rated power; 1, 4, 8 or 16 ohms
- 20 Hz to 20,000 Hz, +0-1.0 dB at rated power; 0.5 and 2 ohms
- 12 Hz to 35,000 Hz, +0 - 1.5 dB at one-half rated power

Mono:

- 20 Hz to 20,000 Hz, +0 - 0.5 dB at rated power; 0.5, 2, 4 or 8 ohms
- 20 Hz to 20,000 Hz, +0-1.0 dB at rated power; 0.25, and 1.0 ohms

12 Hz to 35,000 Hz, +0 - 1.5 dB at one-half rated power

## NOISE AND HUM

90 dB below rated output

## OUTPUT POWER MONITOR METER

Meter is calibrated to read +3 db when amplifier produces 300 RMS watts or 600 peak watts. Meter range switch is provided to increase meter sensitivity by 10 dB or 20 dB.

Meter features special circuit to respond to peak values of complex input signal. Calibration accuracy at 0 dB is  $\pm 2\%$  at all frequencies; meter range accuracy is  $\pm 5\%$ .

## OUTPUT IMPEDANCE

- Stereo: 0.5, 1, 2, 4, 8, and 16 ohms
- Mono: 0.25, 0.5, 1, 2, 4, and 8 ohms

## OUTPUT VOLTAGES

25 volts, stereo and mono; 70 volts, stereo and mono

## DAMPING FACTOR

27 at 0.5 ohm output, 50 at 1 ohm output, 29 at 2 ohm output, 21 at 4 ohm output, 14 at 8 ohm output.

## INPUT IMPEDANCE

200,000 ohms

## INPUT SENSITIVITY

0.5 volts input required to produce rated output. Level control provided for input voltages up to 30 volts.

## POWER REQUIREMENTS

120 volts, 50/60 Hz, 160 watts at zero signal output. 1400 watts at rated output.

## SEMICONDUCTOR COMPLEMENT

46 Silicon transistors, 22 Silicon rectifiers and diodes

## MECHANICAL INFORMATION

**SIZE:** Front panel measures 19 inches wide (48.26 cm) by 10½ inches high (26.67 cm). Chassis measures 17 inches wide (43.18 cm) by 10 inches high (25.4 cm) by 17 inches deep (43.18 cm), including connectors. Clearance in front of mounting panel including knobs 2 inches (5.08 cm)

**FINISH:** Front panel is anodized gold and black. Chassis is black baked enamel.

**MOUNTING:** Standard 19" (48.26 cm) rack mounting.

**WEIGHT:** 128 pounds (58.06 kg) net, 143 pounds (64.86 kg) in shipping carton.

**SPECIAL FEATURES:** The amplifier is completely stable when connected to any loudspeaker system and to any reactive loads. The MC 2300 has special circuits to prevent damage by short circuit or open circuit of the output loads, or by any amount of output impedance mis-match.

Thermal cutouts are mounted on the output transistor heat sinks to provide protection in the event of inadequate ventilation.

# Typical Performance Charts

HARMONIC DISTORTION vs. POWER OUTPUT

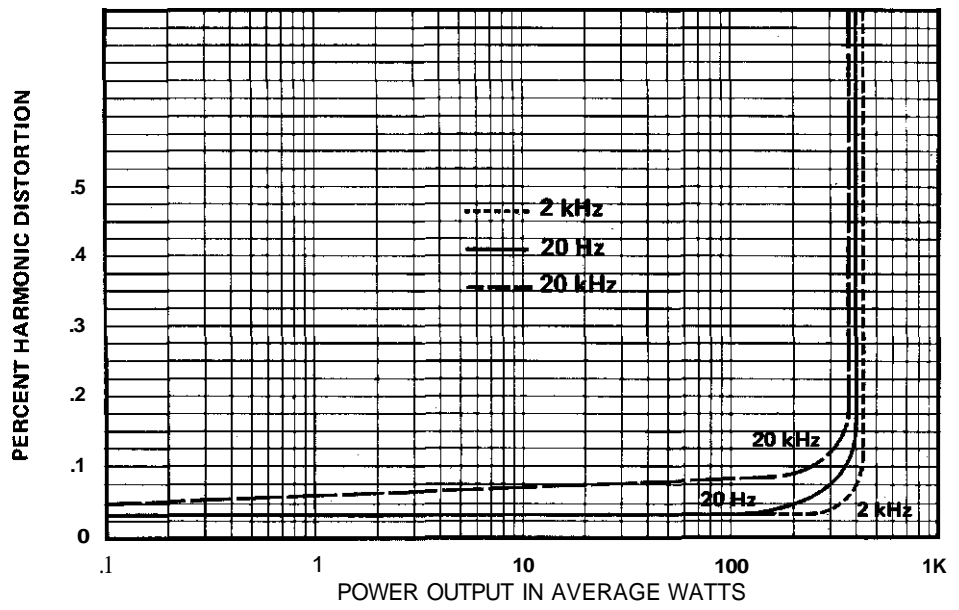

POWER BANDWIDTH

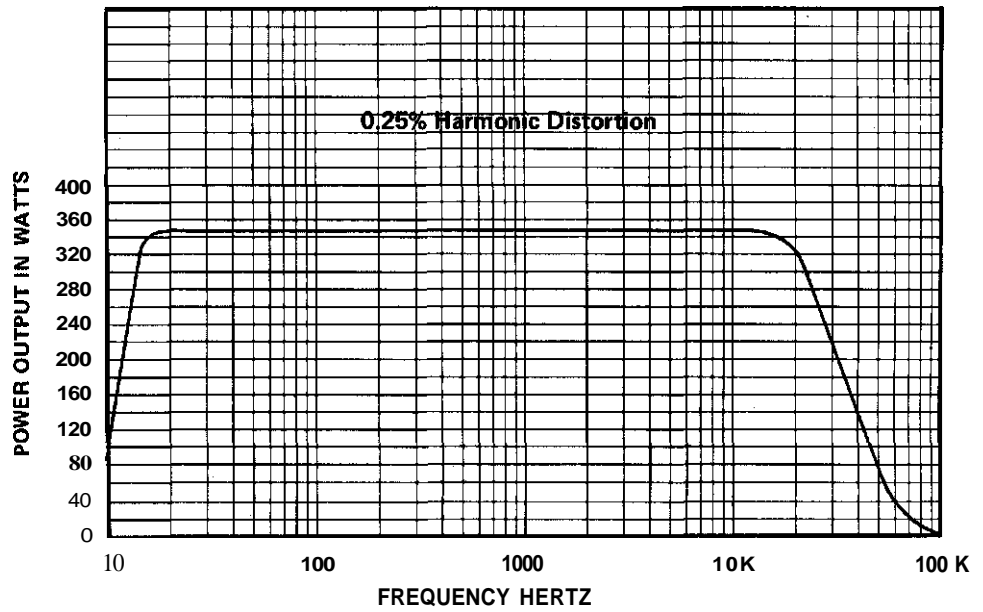

INTERMODULATION DISTORTION

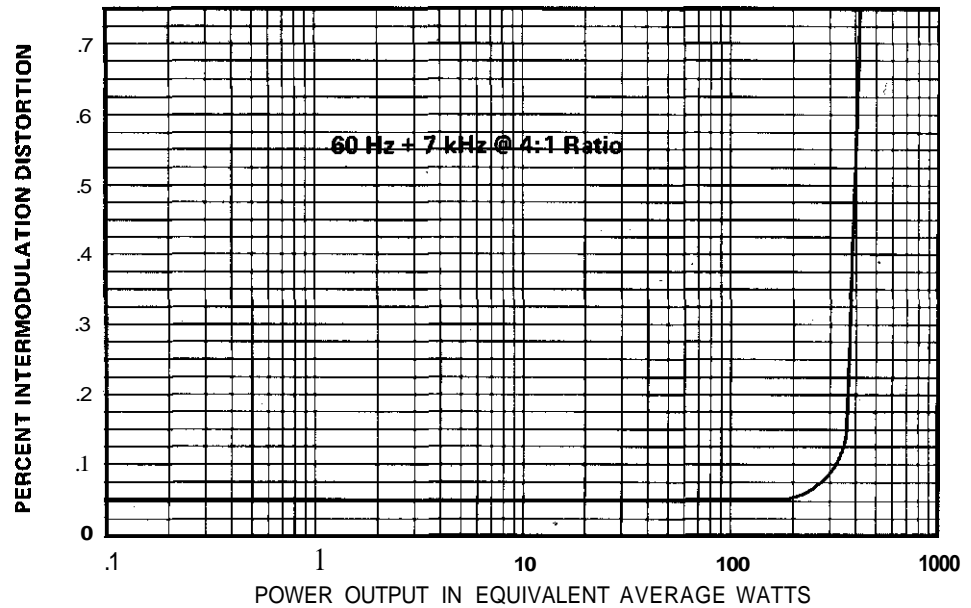

# Technical Description

Each channel of the MC 2300 can be divided into five different sections. These sections are (1) input amplifier, (2) power amplifier circuit, (3) limiter circuit, (4) meter circuit and (5) power supplies.

## INPUT AMPLIFIER

The MC 2300 will deliver rated output from an input signal of 0.5 volts. The input control reduces the amount of signal into the input amplifier as the setting is reduced. By the correct setting of the control input signals on the order of 30 volts can be applied to the input of the MC 2300 without overdriving the input. At the input amplifier two NPN transistors, Q2 and Q4, are connected in a differential amplifier arrangement. The two inputs to the differential amplifier are the input signal and the feedback signal from the output of the input amplifier. The use of a differential amplifier provides the most efficient use of larger amounts of negative feedback to maintain low noise and distortion. The combined output of the differential amplifier feeds a common emitter voltage amplifier Q6. The output of the Q6 is coupled via a large value capacitor to the power circuit and to the feedback input of the differential amplifier. A large value capacitor is used to assure good low frequency reproduction and to assure that no DC is coupled to the power amplifier circuits. From the collector of Q6 the resistors R20 and R18 form a dividing network which determines the amount of negative feedback fed to the differential amplifier. The path provides both AC and DC feedback. A small trimming capacitor parallels R20 to increase the amount of feedback

at frequencies above 50,000 Hz. This increased feedback reduces the noise level of the input section where the signal to noise level is more critical, it also rolls off the frequency response above 50,000 Hz. Resistors R9 and R10 with C5 C6 form a filter chain to filter the  $\pm 21$  volts used to supply the input amplifier. Left and right channels operate identically. The output of the left and right input amplifiers is fed to the mono/stereo switch.

## OPERATION OF MONO/STEREO SWITCH

If the MODE switch is in the STEREO position each input amplifier is directly connected to its respective power amplifier. In the MONO position the output of the right channel input amplifier is fed to both left and right power amplifiers, the LEFT INPUT is disconnected. For stereo or twin channel operation the MC 2300 has two independent amplifying sections. Consequently, each amplifier output can be loaded with any desired impedance load. For MONO operation the two power amplifier output sections are connected together for parallel operation. The output load therefore must be connected to the output of each channel strapped together in parallel. Should the MODE switch be left in the STEREO position and the output transformers be strapped to a mono load, one channel will attempt to drive the other and cause high circulating currents and overheating. **Be certain that the MC 2300 is never operated in the stereo mode with the outputs strapped in parallel.**

## POWER AMPLIFIER

At the right input channel power amplifier input, two PNP transistors (Q102 and Q104) are connected in a differential amplifier configuration. As in the

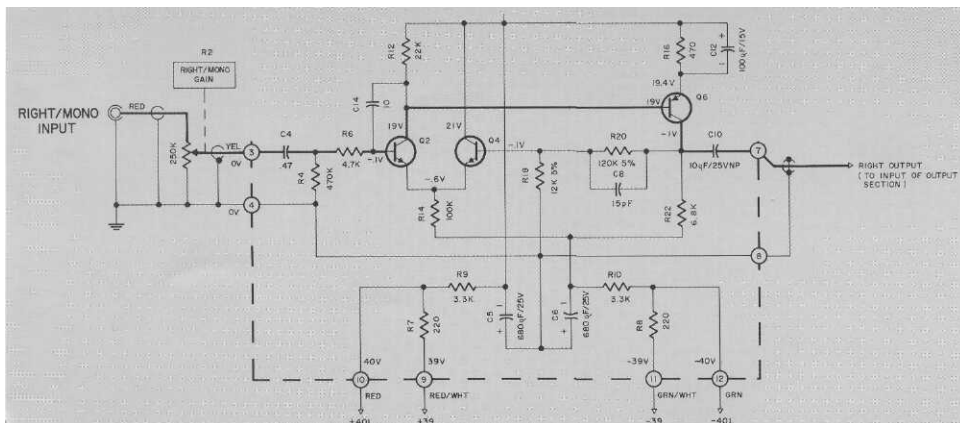

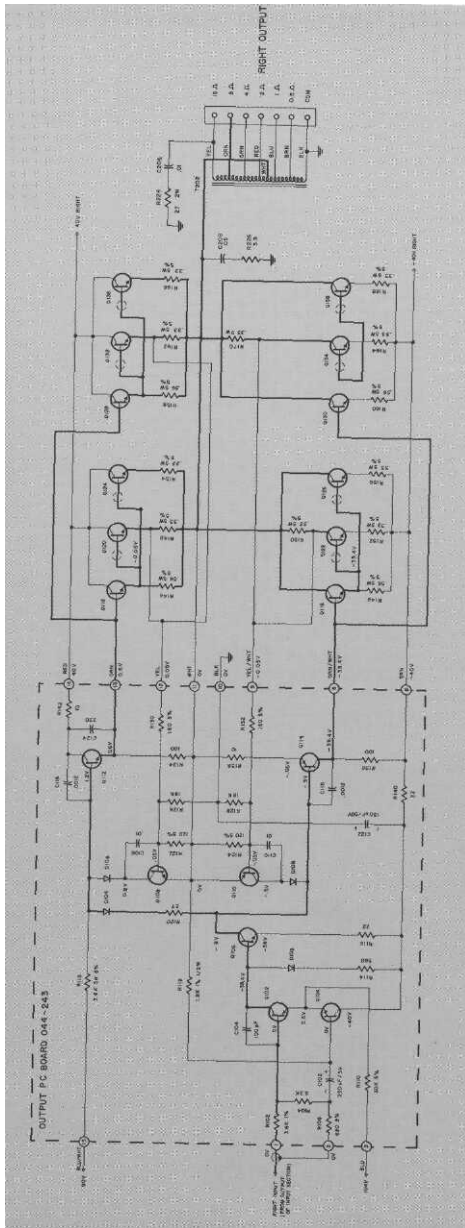

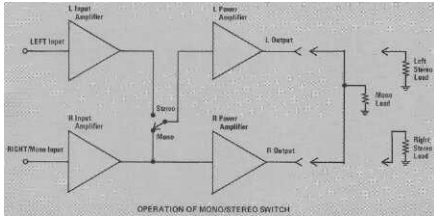

input amplifier the two signals to the differential amplifier are the normal power amplifier input signal and the negative feedback signal from the power amplifier output. The combined output of the differential amplifier feeds transistor Q106 which is a common emitter Class A linear voltage amplifier. The output of Q106 is directly coupled to the bases of transistors Q112 and Q118 which are NPN and PNP complementary medium power driver transistors. The driver stages furnish the current required to the bases of the output transistors Q116 thru Q138. Output transistors Q116, 120, and 124, 128, 132, 136 con-

trol the positive portion of the output signal while transistors Q118, 122, 126, 130, 134, 138 control the negative half of the output signal. These 12 output transistors work together forming a series push-pull output capable of delivering extremely high currents. The output transistors are mounted on oversized black anodized heat sinks. Two long life quiet running fans draw air over the heat sinks and out the rear of the unit. With all covers in place the MC 2300 will run relatively cool even under full load conditions. Resistor R112 completes the DC negative feedback path to the differential input while the resistors R112 and R106 form a voltage divider network for the AC negative feedback.

A high value resistor, R118, in series with a high voltage power supply acts as a current source for the driver transistors Q112 and Q114. The dual diode D104 and resistor R27 set the standing current for all of the output transistors to achieve Class B operation. Driver transistor Q112 is physically mounted atop the dual junction diode D104 causing the junction voltage drop to decrease as the diode is heated. This change in voltage causes the standing current to remain constant regardless of the operating temperatures.

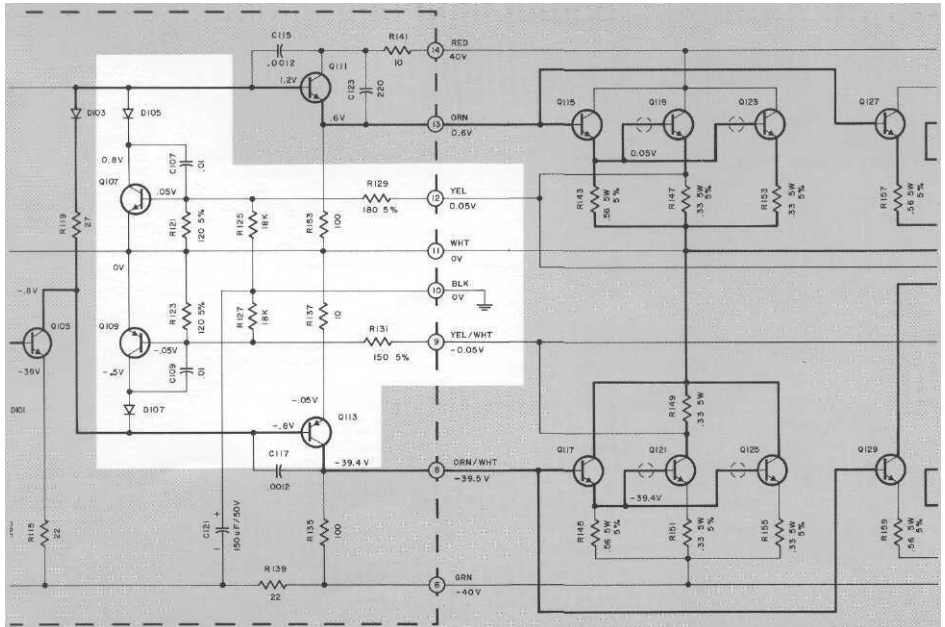

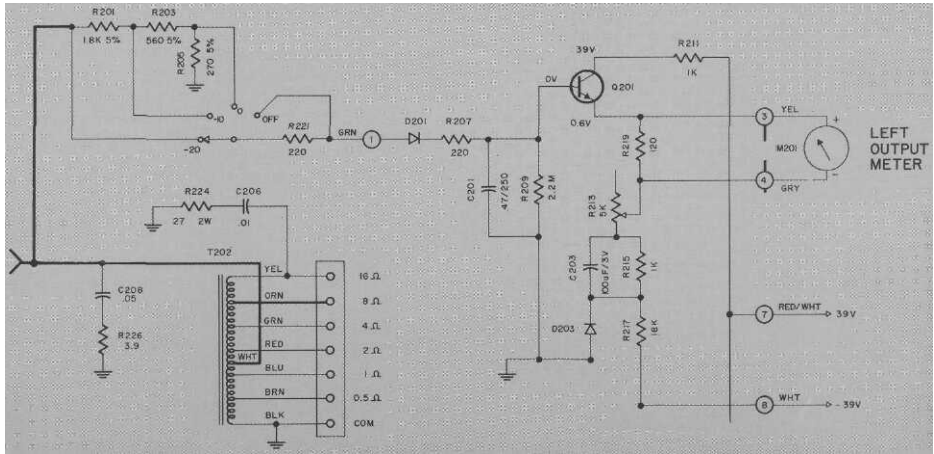

### LIMITER CIRCUIT

In the power amplifier circuit the amount of signal output has a linear relationship with the input signal. In the event of a short circuit or severe impedance mismatch the limiter circuit will protect the output transistors against failure. The McIntosh patented Sentry Monitoring circuit constantly monitors the output signal and instantly reacts to prevent overload to the output transistors. At signal levels up to rated output the limiter circuit is a high impedance circuit in all modes and has no effect upon the output signal. If the power output exceeds the design limits the limiter circuit becomes low impedance and reduces the signal to the output transistors.

Both positive and negative halves of the output are monitored independently and the circuit operation is similar for both halves. The amount of current flowing through an output transistor is monitored by sensing the voltage measured across the emitter (positive) or collector (negative) resistor relative to the output buss. This voltage is applied to the base of the limiter transistor Q107 (positive) and/or Q109 (negative) via the voltage dividing network R121, 129 (positive) and/or R123, R131 (negative). When the current flowing in the output attempts to exceed the design limits then the voltage at the base of the limiter transistors causes those transistors to conduct making a portion of the signal to the base of the driver transistors Q111 (positive) and Q113 (negative) to be drained off.

### METER CIRCUIT

Ordinary meters lack the capability of indicating the short interval of power in a sound wave. The mass of the meter movement is too great to respond to the

nearly instantaneous changes in music program material. McIntosh has developed circuits that permit the meters of the MC 2300 to respond to the short interval power in a sound wave to an accuracy of 98%.

Monitoring of the output power is done at the primary or input of the autoformer. Sampling the output power in this portion of the circuit gives true power readings regardless of output impedance selected. To be able to read power peaks that are sustained for such extremely short durations, McIntosh engineers developed circuits that accelerated the upswing of the meter and caused the needle to be held at the peak reading long enough for the human eye to perceive the indication of the needle. The McIntosh meter circuit is a dynamic peak locking meter circuit that does both things. (Patented)

Diode D203 and resistor R217 tied to the negative supply place a bias on the emitter of transistor Q201 to hold the transistor just at the threshold of conduction. Diode D201 passes only the positive portions of the input signal to the base of Q201 charging the capacitor C201. Since the transistor Q201 is on the edge of conduction the slightest positive swing of input signal causes conduction to begin. The largest capacitor C203 in the emitter circuit will appear as a direct short at first to the negative supply thereby accelerating the needle of the meter upscale. At the peak of the signal the needle will stop its upswing. When the meter needle reaches peak and the input signal starts a downswing, the capacitor C201 starts to lose its charge by the RC time constant of C201, R209. For that amount of time a positive charge is supplied to the base of Q201 causing it to conduct for a longer length of time. The RC combination R215,



C203 act as a meter upswing accelerator while the RC combination R209, C201 act as a pulse or time stretching aid. Variable resistor R213 is used to adjust the meter to read exactly "+3" at 300 watts RMS. All components of the meter circuit have been selected and designed to have maximum flat response at the frequency extremes. A reading of a given power is correct regardless of the frequency of the signal. The MC 2300 contains two independent meters and meter circuits. Both meter circuits operate the same and are completely independent except for meter range setting. The meter range switch does not alter the sensitivity of the meter circuit but attenuates, by the correct ratio, the amount of input signal to the meter circuit.

## POWER SUPPLIES

To deliver rated power at frequency extremes, design of a power amplifier supply must have good regulation and ample reserve. At lower frequencies the power supply capacitors must be of sufficient size to deliver full voltage, cycle after cycle, with no increase in ripple. At higher frequencies power transistors require more power. The power supply must be able to furnish the additional power without sacrificing regulation or overheating. In all cases the

power furnished to one channel should have no effect upon the performance of second channel. Any effect would cause cross talk and poor channel separation. In stereo use a stereo power amplifier must act as two separate amplifiers whether their power signals are common or separate. This design goal is fully achieved in the MC 2300.

In the McIntosh MC 2300 two high current supplies are used. Each high current supply furnishes the positive and negative forty volts required in the power output circuits. The four 39,000 microfarad capacitors store ample power (over 120 joules) for frequencies in the low range. The power transformer has been designed to run relatively cool at full power output. Bridge rectifiers D301 and D302 are used in both high current supplies for most efficient conversion of power.

A high voltage lower current supply is designed to furnish power to the lower level and driver circuits. Full wave recification and considerable filtering assure clean signal amplification with no added hum or noise.

A resettable circuit breaker in the primary of the power transformer and two heat sensing switches S302, S303 protect the amplifier against overload and/or overheat.

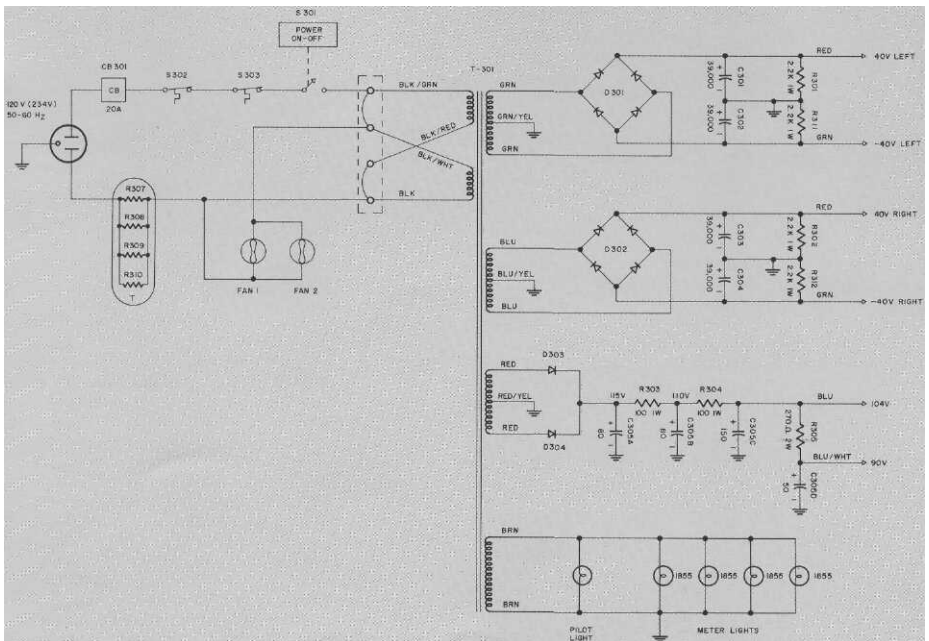

# Block Diagram

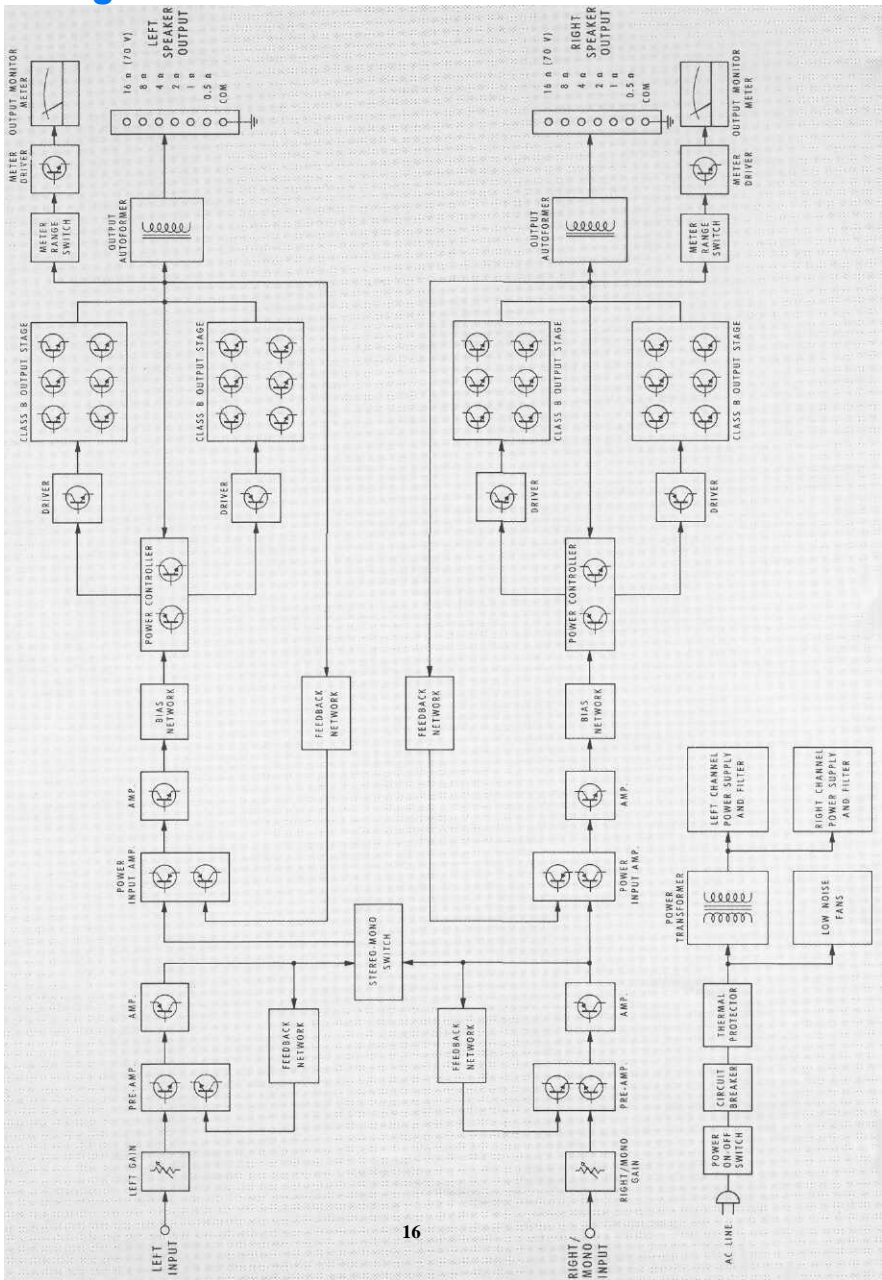



# McIntosh

MCINTOSH LABORATORY INC.  
2 CHAMBERS ST., BINGHAMTON, N. Y. 13903

**607-723-3512**

Design subject to change without notice.

Printed in U.S.A.

038-662